



tET-P2POR2
tET-PD2POR2

tPET-P2POR2
tPET-PD2POR2

Tiny Ethernet Module with 2-ch DI, 2-ch PhotoMOS Relay

Features

- Web Server for Configuration
- Cost-effective Tiny Ethernet I/O Modules
- Support Modbus TCP/UDP and MQTT Protocols
- I/O Pair Connection (Push and Pull)
- Redundant Power Inputs: PoE (IEEE 802.3af, Class 1) and DC input
- Supports Dual-watchdog
- Supports Firmware Update via Ethernet
- Supports Latched DI, 32-bit DI Counters, and Frequency Measurement
- DO Power-on and Safe Value



Introduction

The **tET/tPET** series is an IP-based Ethernet I/O monitoring and control module. The module can be remotely controlled through a 10/100 M Ethernet network by using Modbus TCP protocol.

The functionality of the tET/tPET series is almost the same as the ET-7000/PET-7000 series. The module can be used to create DI to DO pair-connect through the Ethernet. Once the configuration is completed, the tET/tPET series module can poll the status of the local DI channels and then use the Modbus/TCP protocol to continuously write to a remote DO device in the background.

The tET/tPET series provides a Supports Dual-watchdog: CPU watchdog and host watchdog. The CPU watchdog automatically resets itself when the built-in firmware runs abnormally. The host watchdog monitors the host controller (PC or PLC), and the output of the module can go to a predefined state (safe value) when the host fails.

It features a powerful 32-bit ARM MCU to handle efficient network trafficking. The **tPET** series offers true IEEE 802.3af-compliant (classification, Class 1) Power over Ethernet (PoE) using a standard category 5 Ethernet cable to receive power from a PoE switch like the NS-205PSE. When there is no PoE switch on site, the tPET series accepts power input from the DC adapter.

System Specifications

Model	tET-P2POR2 tET-PD2POR2	tPET-P2POR2 tPET-PD2POR2
Software		
Built-in Web Server	Yes	
CPU Module		
CPU	32-bit MCU	
Watchdog Timer	Module, Communication (Programmable)	
EMS Protection		
EFT (IEC 61000-4-4)	±4 kV for Power Line	
ESD (IEC 61000-4-2)	±4 kV Contact for Each Terminal ±8 kV Air for Random Point	
LED Indicators		
Status	Run, Ethernet	Run, Ethernet, PoE
Ethernet		
Ports	1 x RJ-45, 10/100 Base-TX	
PoE	-	Yes
Access Control	Password and IP Filter	
Protocol	Modbus TCP, Modbus UDP, MQTT	
Power		
Reverse Polarity Protection	Yes	
Consumption	0.9 W	1.0 W
Powered from PoE	-	IEEE 802.3af, Class 1
Powered from Terminal Block	+12 to +48 VDC	

Mechanical	
Dimensions (mm)	52 x 95 x 27 (W x L x H)
Installation	DIN-Rail mounting
Environment	
Operating Temperature	-25 ~ +75 °C
Storage Temperature	-30 ~ +80 °C
Humidity	10 ~ 90% RH, Non-condensing

Dimensions (Units: mm)

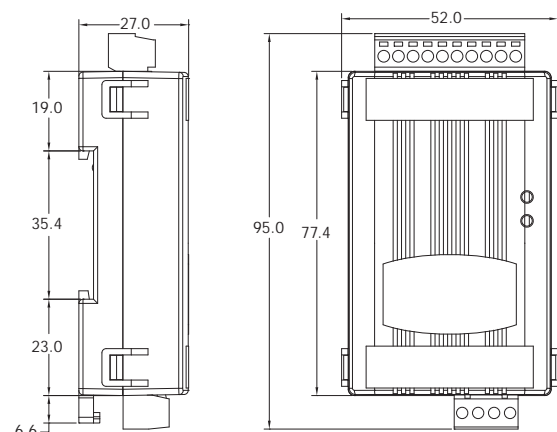

I/O Specifications

Model	t(P)ET-P2POR2	t(P)ET-PD2POR2
Digital Input/Counter		
Channels	2	
Type	Wet Contact	Dry Contact
Sink/Source (NPN/PNP)	Sink/Source	Source
ON Voltage Level	+10 to +50 VDC	Close to GND
OFF Voltage Level	+4 VDC (max.)	Open
Max. Counts	4,294,967,295 (32-bit)	
Frequency	3.5 kHz (without filter)	
Min. Pulse Width	0.15 ms	
Effective Distance	-	500m (max.)
Isolation	3750 Vrms	
Input Impedance	10 kΩ	-
Overvoltage Protection	+70 VDC	-

Model	t(P)ET-P2POR2	t(P)ET-PD2POR2
Relay Output		
Channels	2	
Type	PhotoMOS Relay, Form A	
Contact Rating	60V/1.0A (Operating Temperature -25 to +40°C) 60V/0.8A (Operating Temperature +40 to +60°C) 60V/0.7A (Operating Temperature +60 to +75°C)	
Operate Time	1.3 ms (Typical)	
Release Time	0.1 ms (Typical)	
Electrical Endurance	Long Life and No Sparking	
Isolation	3000 Vrms	

Wire Connections

t(P)ET-P2POR2		
Digital Input	Readback as 1	Readback as 0
Sink	+10 ~ +50 VDC 	OPEN or <4 VDC
	+10 ~ +50 VDC 	OPEN or <4 VDC

t(P)ET-PD2POR2		
Digital Input	Readback as 0	Readback as 1
Dry Contact	Relay OFF 	Relay ON

t(P)ET-P2POR2 / t(P)ET-PD2POR2		
Digital Output	Readback as 1	Readback as 0
Form A Relay Contact	Relay ON 	Relay OFF

Pin Assignments

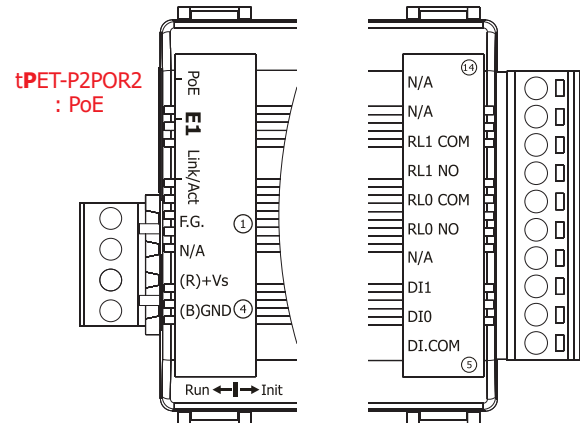

Bottom

Top

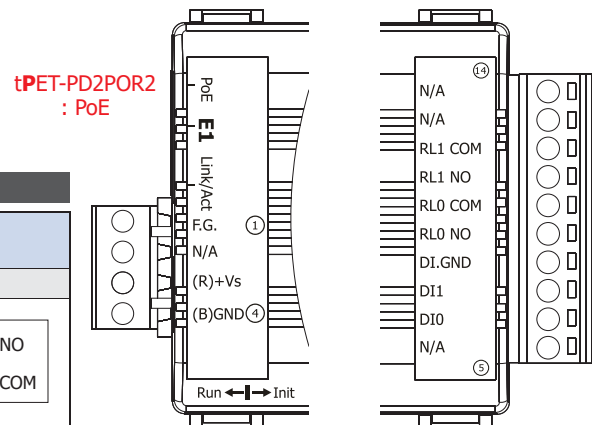

Ordering Information

tET-P2POR2 CR	Tiny Ethernet module with 2-ch DI (Wet), 2-ch PhotoMOS Relay (RoHS)
tET-PD2POR2 CR	Tiny Ethernet Module with 2-ch DI (Dry) , 2-ch PhotoMOS Relay (RoHS)
tPET-P2POR2 CR	Tiny PoE Ethernet Module with 2-ch DI (Wet), 2-ch PhotoMOS Relay (RoHS)
tPET-PD2POR2 CR	Tiny PoE Ethernet Module with 2-ch DI (Dry), 2-ch PhotoMOS Relay (RoHS)